

DLED-1565

120V-277V AC

6" COB LED Surface Cylinders with Wide Beam Reflector



Catalog #		Type
Project		Date
Prepared by		

6" LED Cylinder

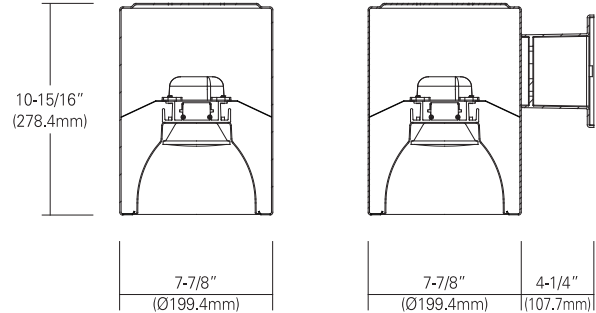

[Ceiling Mount : DLED-1565C] [Wall Mount : DLED-1565LC]

DESCRIPTION

6" aperture cylinder light, Provided in high efficacy LED with integral driver and the optical diffusion produces high lumen transmission and even illumination. Designed for long life operation.

SPECIFICATION

LED Quantity	1EA (COB)		
Input Voltage	120V-277V AC		
Wattage (Typ)	14 W	22 W	33 W
Lumen (Typ)	1,400	1,980	2,970
Efficacy (LPW)	100 lm/W	90 lm/W	90 lm/W
Beam Angle	65°		
C R I (Typical)	80, 90		
Color (+/-5%)	2700K, 3000K, 4000K, 5000K		
Dimming	Triac & 0-10V the both(Consult with factory for approved dimmers)		

FEATURES and FUNCTIONS

- Durable aluminum extrusion heat sink intergrated with COB (chip on board).
- Include 120~277V input high efficacy driver with the capability.
- Driver feature power factor >.90, THD <20% and has integral thermal protection to sense over temperature or internal failure.
- Driver mounts externally to the module, allowing future replacement, if needed.
- Triac and 0-10V dimmable.

Listing

- ETL & cETL Listed
- State of California Title 24
- Energy star Approved & Listed
- Damp location

Warranty

- 5years of lamp life.

ORDERING INFORMATION

Housing	Pendant Stem Length	Watts	CRI	CCT	Driver	Housing Finish	Reflector Finish	Optional Baffle Finish
DLED-1565C Ceiling Mount	12 12 Inches	14 14W	8 80	27 2700K	UTD 120V, Triac Dimming (Standard)	WH White BK Black BZ Bronze SI Silver	HC Haze Clear WH White	WH White BK Black
DLED-1565LC Wall Mount	18 18 Inches	22 22W	9 90	30 3000K				
DLED-1565PC Pendant Mount	24 24 Inches	33 33W		40 4000K	UZTD 120~277V, 0-10V Dimming			
	36 36 Inches			50 5000K				
	48 48 Inches							
		*For Pendant Mount Only						
*Consult with factory for custom finishes								

Example : DLED-1565PC-12-14-840-UTD-WH-HC

- - - - - -